

# HG100G

## DEMAND SAFETY

The Hyde GUARDIAN Gold™ Ballast Water Treatment system is an effective and reliable solution combining filtration with Ultraviolet (UV) disinfection.

### HG100G Features:

- Smallest footprint on the market
- Optimized size for smaller vessels
- Seven automatic modes of operation for one-touch operation
- Two-sided chamber reduces maintenance space requirements
- Automatic backflushing filter capable of handling heavy organic and sediment loading
- Produces no harmful disinfection by-products

### What's Included:

- Filter
- UV Chamber
- Control Panel
- Power Panel
- Control valves
- Flow meter
- Air supply regulator

### Options available:

- Skid mounting (includes interconnect piping and wiring)
- Hazardous Area certification available
- Easy interface with ships automation
- Isokinetic Sample Port(s)
- Remote Panels



The HG100GS assembly mounts major components for ease of installation.

Technical Data	
Treatment Rated Capacity	100 m <sup>3</sup> /hr
Electrical Supply	380 – 690V · 50/60 Hz · 3 ph
Power Consumption	11 kW Nominal · 20 kW max
Max. Operating Pressure	10 bar
Minimum Flow	10 m <sup>3</sup> /hr
Max. Operating Temperature	55 C

Component	Size (L · W · H) (mm)	Weight (kg)
Skid (Complete Assembly)	1617 · 1028 · 2164	960
Filter	413 · 456 · 1050	131
UV Chamber	1186 · 949 · 587	165
Control Panel	600 · 210 · 760	35
Power Panel	1206 · 406 · 1803	363

FRONT VIEW

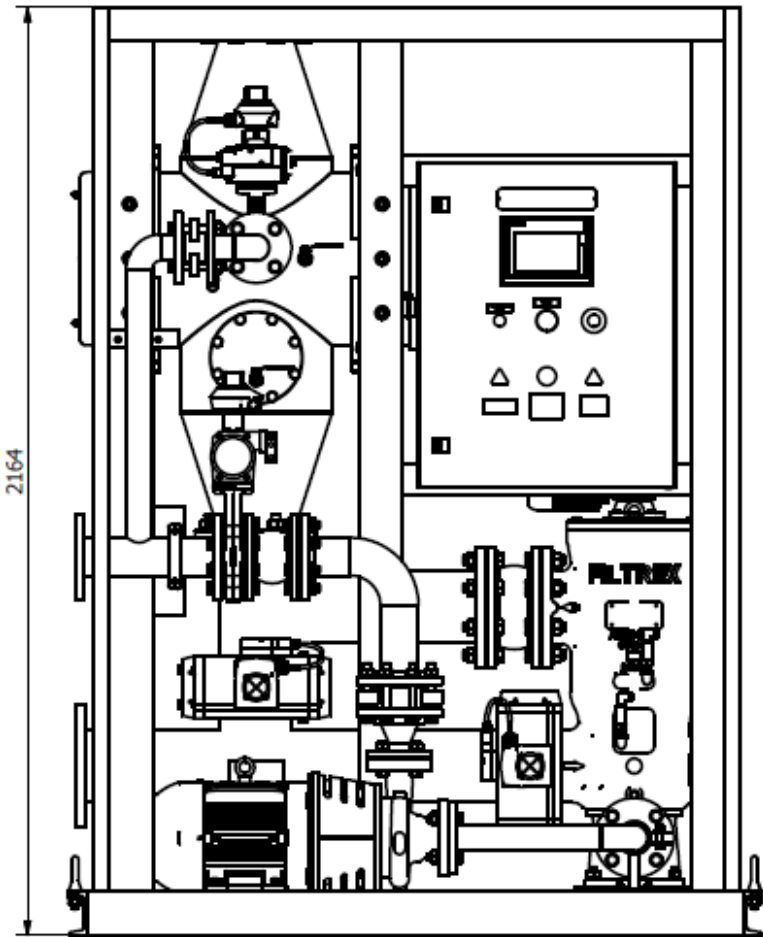

SIDE VIEW

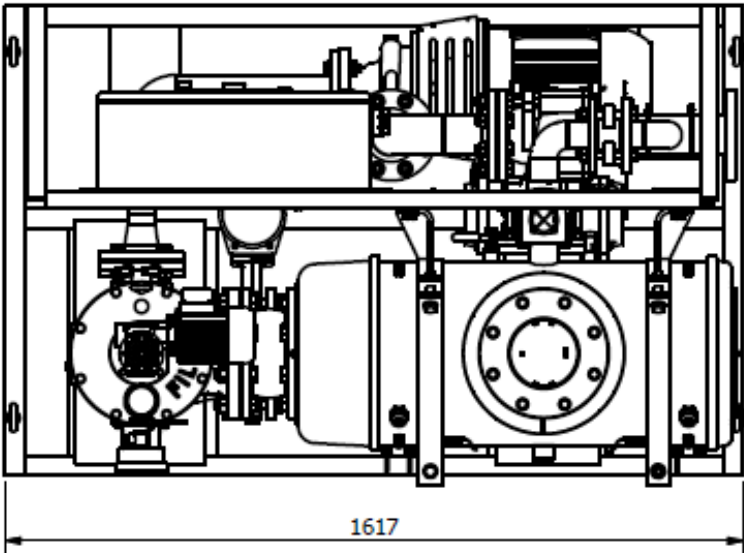
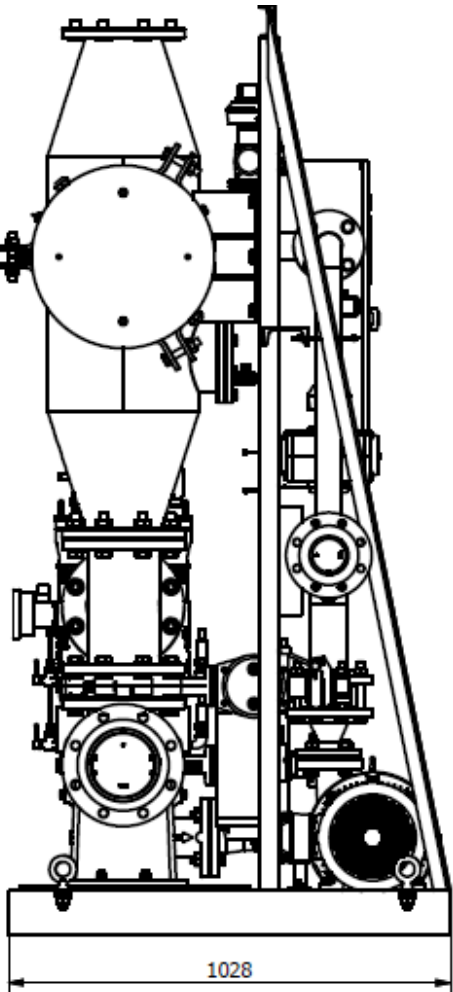

TOP VIEW